

Intelligent Sounder Beacon Base

The intelligent sounder beacon base is a low profile base sounder with combined 360° visual indicator. By utilising a fully digital communication protocol, reliable and fast operation is achieved even when employing the impressive 240 device loop capacity.

Once installed onto a compatible loop, the device is fully addressable and benefits from an extensive range of intelligent functionality, including sounder synchronisation. The unit's integral detector base has easy access for loop cabling and allows for the connection of both the sounder and associated detector via a single set of cable terminations.

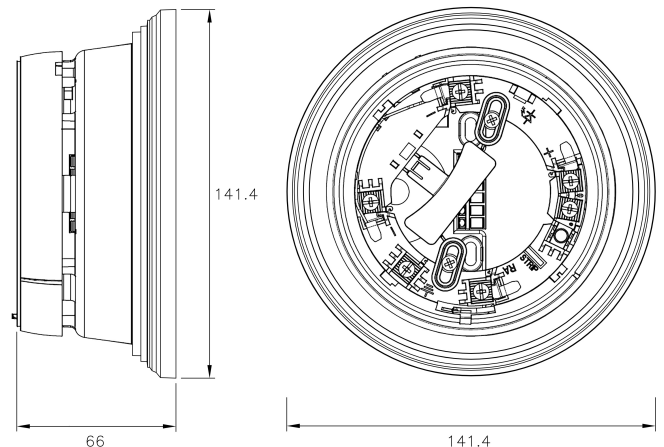
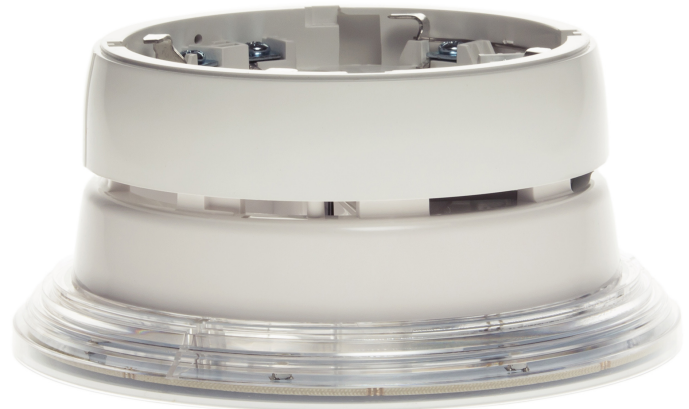

Features

- 32 programmable tones
- Built-in loop isolators
- Fully intelligent
- 360 degree visibility of VID when activated
- Synchronised sounder
- Adjustable volume output
- Auto-addressable
- Programmable via device programming tool
- Includes device identification tab
- Easy central cable entry
- Low profile design

Specification

Standby current	70µA @ 24 Vdc
Loop voltage range	15 Vdc - 32 Vdc (typically 24 Vdc)
Current consumption (activated - dual tone and beacon on)	5-8 mA @ 24 Vdc
Maximum volume	94 dB @ 1 metre
Tone range	440 Hz - 2900 Hz
Operating temperature range	-10°C to +55°C
Dimensions (W x D)	141.4 x 66 mm
Weight	220 g
Maximum humidity (non condensing)	95% RH
Maximum number of loop addresses	240

Order Codes and Options

Axis-SVMB

Intelligent Sounder Beacon Base

[Check if this document is up to date](#) | [Give us feedback](#)

Advanced, Moorland Way, Cramlington, Northumberland, NE23 1WE, UK T: +44 (0)1670 707 111, E: enquiries@advancedco.com, W: www.advancedco.com

As our policy is one of constant product improvement the right is therefore reserved to modify product specifications without prior notice.